















# UTTERMOST

## ASSEMBLY INSTRUCTIONS

ITEM: 23822

PARTS LIST							
NO	DRAWING	PARTS NAME	Q'TY	NO	PARTS NAME	DRAWING	Q'TY
A		FLAT WASHER 5/16" * 3/4"	8PCS	1	SEAT ASSEMBLY		1PC
B		LOCK WASHER 5/16"	8PCS	2	LEFT LEG		1PC
C		BOLTS DIA 5/16" * 2"	4PCS	3	RIGHT LEG		1PC
D		BOLTS DIA 5/16" * 3"	4PCS	4	SEAT FRAME		1PC
E		ALLEN WRENCH 5/16"	1PC	5	CAPRAIL		1PC
F		SCREW #8*1-3/4"	6PCS	6	FRONT RAIL		1PC
G		SCREW #8*3/4"	4PCS	7	BACK RAIL		1PC

ASSEMBLY BOLTS MAY NEED TIGHTEND AFTER USE

### STEP 1

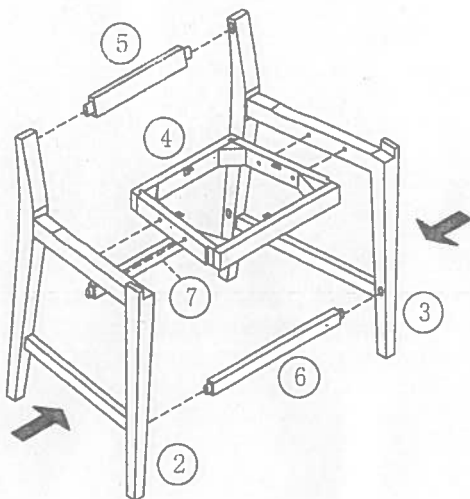

### STEP 2

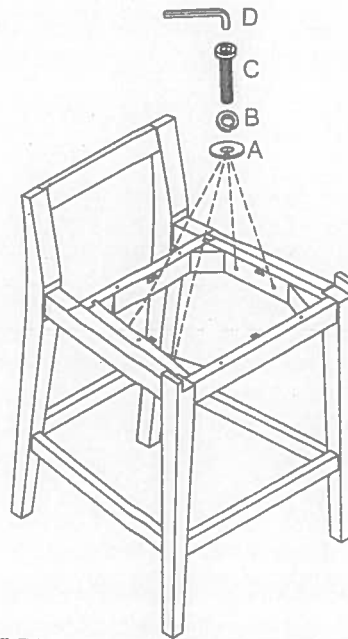

### STEP 3

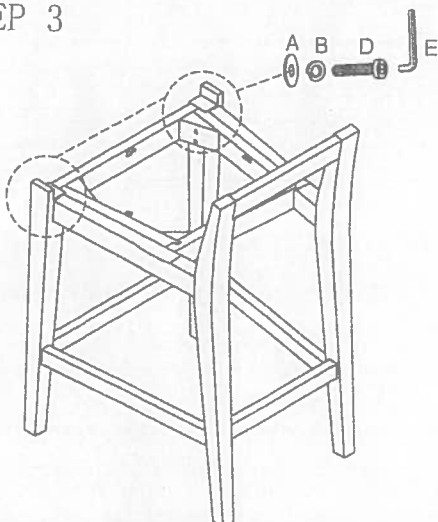

### STEP 4

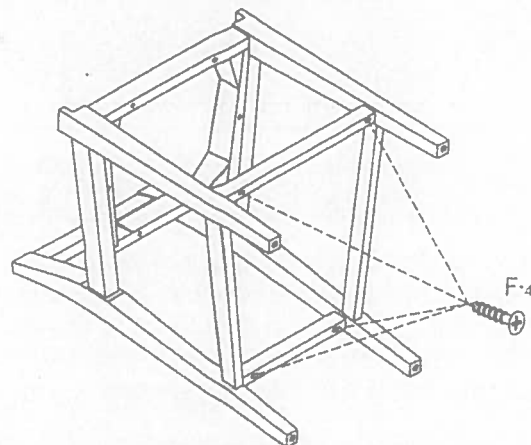

# UTTERMOST

## ASSEMBLY INSTRUCTIONS

ITEM: 23822

STEP 5

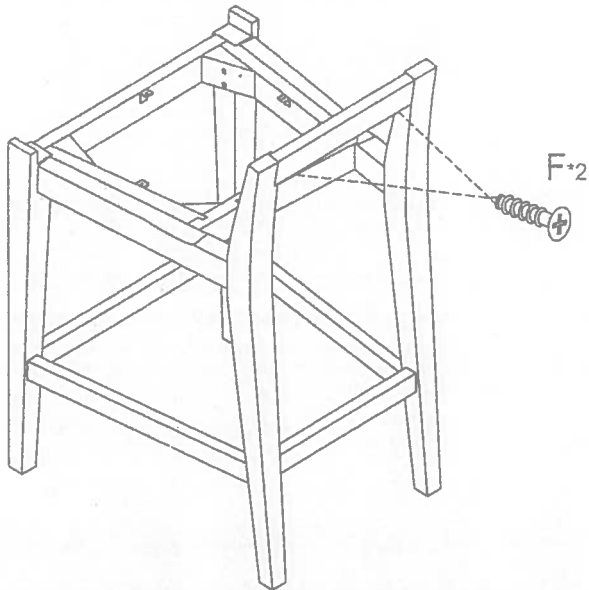

STEP 6

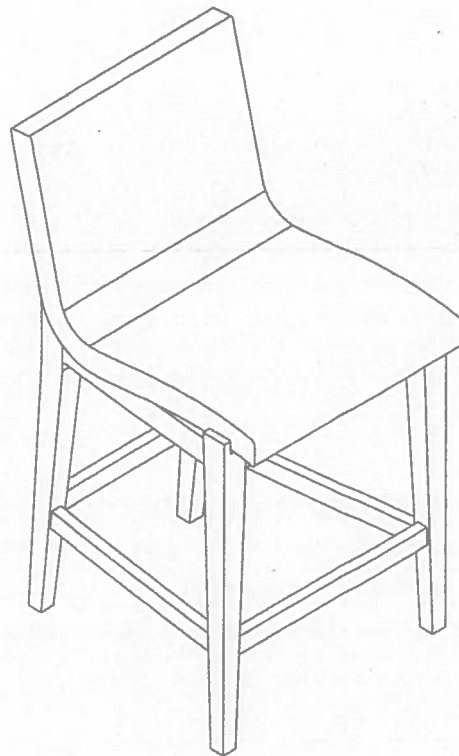
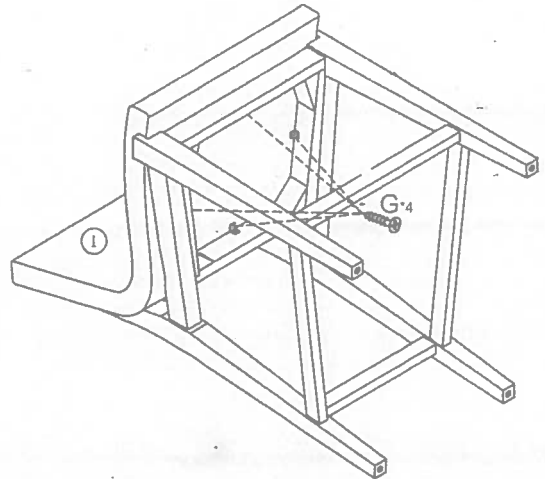

To avoid wobbly product and gaps between legs and stretchers, please follow below steps to assemble:

- 1) Attach the legs. Do not completely tighten the bolts that hold the legs.
- 2) Attached the stretchers. Completely tighten the screws that hold the stretchers.
- 3) Set the chair on the floor to level and then finish tightening the leg bolts